

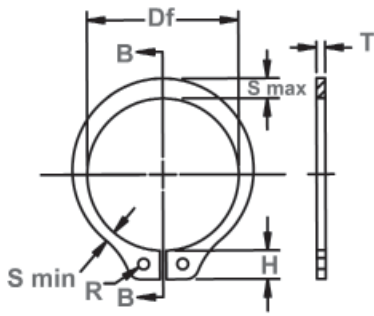

# SH Shaft Rings

**Axially Assembled, External**  
 Once installed in the groove of a shaft, the portion of the ring protruding from the groove (also called a "shoulder") holds an assembly in place.



Free Diameter & Ring Measurements with Section B-B

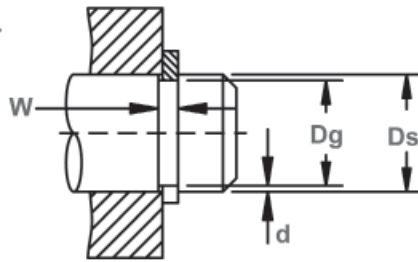

Shaft Diameter & Groove Dimensions

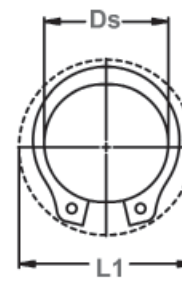

Clearance Diameter Expanded Over Shaft



Clearance Diameter & Gaging Diameter Released in Groove.

RING NO.	SHAFT DIAMETER			GROOVE SIZE			RING SIZE & WEIGHT				CLEARANCE DIA.			THRUST LD. (lbs.)			
				DIAMETER		WIDTH		DEPTH	FREE DIAMETER		THICKNESS***		Weight Per 1000 pcs.	Expanded over Shaft	Re-leased in Groove	Sqr. Corner Abutment	
	Ds DEC	Ds FRAC	Ds mm	Dg	Tol.	W	Tol.	d	Df	Tol.	T	Tol.				lbs.	L1
**SH-12	.125	1/8	3.2	.117		.012		.004	.112		.010	±.001	.018	.222	.214	112	35
**SH-15	.156	5/32	4.0	.146		.012		.005	.142		.010		.037	.27	.260	132	55
**SH-18	.188	3/16	4.8	.175	±.0015	.018	+.002	.006	.168	+.002	.015		.059	.298	.286	244	80
**SH-19	.197	-	5.0	.185	.0015*	.018	-.000	.006	.179	-.004	.015		.063	.319	.307	254	85
**SH-21	.219	7/32	5.6	.205		.018		.007	.196		.015		.074	.338	.324	284	110
**SH-23	.236	15/64	6.0	.222		.018		.007	.215		.015		.086	.355	.341	315	120
SH-25	.250	1/4	6.4	.230		.029		.010	.225		.025		.21	.45	.43	599	175
SH-27	.276	-	7.0	.255		.029		.010	.250		.025		.23	.48	.46	660	195
SH-28	.281	9/32	7.1	.261		.029		.010	.256		.025		.24	.49	.47	670	200
SH-31	.312	5/16	7.9	.290		.029		.011	.281		.025		.27	.54	.52	751	240
SH-34	.344	11/32	8.7	.321	±.002	.029		.011	.309		.025		.31	.57	.55	812	265
SH-35	.354	-	9.0	.330	.002*	.029		.012	.320	+.002	.025		.35	.59	.57	832	300
SH-37	.375	3/8	9.5	.352		.029		.012	.338	-.005	.025		.39	.61	.59	883	320
SH-39	.394	-	10.0	.369		.029		.012	.354		.025		.42	.62	.60	954	335
SH-40	.406	13/32	10.3	.382		.029		.012	.366		.025		.43	.63	.61	964	350
SH-43	.438	7/16	11.1	.412		.029		.013	.395		.025		.50	.66	.64	1035	400
SH-46SP1	.461	-	11.7	.435		.029		.013	.420		.025		.51	.68	.66	1110	460
SH-46	.469	15/32	11.9	.443		.029		.013	.428		.025	±.002	.54	.68	.66	1117	450
SH-50	.500	1/2	12.7	.468	±.002	.039	+.003	.016	.461		.035		.91	.77	.74	1675	550
SH-55	.551	-	14.0	.519	.004*	.039	-.000	.016	.509		.035		.90	.81	.78	1800	600
SH-56	.562	9/16	14.3	.530		.039		.016	.521		.035		1.1	.82	.79	1878	650
SH-59	.594	19/32	15.1	.559		.039		.017	.550		.035		1.2	.86	.83	1979	750
SH-62	.625	5/8	15.9	.588		.039		.018	.579		.035		1.3	.90	.87	2091	800
SH-66	.669	-	17.0	.629		.039		.020	.621	+.005	.035		1.4	.93	.89	2233	950
SH-66	.672	43/64	17.1	.631		.039		.020	.621	-.010	.035		1.4	.93	.89	2233	950
SH-68	.688	11/16	17.5	.646		.046		.021	.635		.042		1.8	1.01	.97	3451	1000
SH-75	.750	3/4	19.0	.704	±.003	.046		.023	.693		.042		2.1	1.09	1.05	3756	1200
SH-78	.781	25/32	19.8	.733	.004*	.046		.024	.722		.042		2.2	1.12	1.08	3959	1300
SH-81	.812	13/16	20.6	.762		.046		.025	.751		.042		2.5	1.15	1.10	4060	1450
SH-84	.844	-	21.4	.791		.046		.026	.780		.042		2.7	1.18	1.13	4200	1500
SH-87	.875	7/8	22.2	.821		.046		.027	.810		.042		2.8	1.21	1.16	4365	1650
SH-93	.938	15/16	23.8	.882		.046		.028	.867		.042		3.1	1.34	1.29	4720	1850
SH-98	.984	63/64	25.0	.926		.046		.029	.910		.042		3.5	1.39	1.34	4923	2000
SH-100	1.000	1	25.4	.940		.046		.030	.925		.042		3.6	1.41	1.35	5024	2100
SH-102	1.023	-	26.0	.961		.046		.031	.946		.042		3.9	1.43	1.37	5126	2250
SH-106	1.062	1-1/16	27.0	.998	±.004	.056	+.004	.032	.982	+.010	.050		4.8	1.50	1.44	6293	2400
SH-112	1.125	1-1/8	28.6	1.059	.005*	.056	-.000	.033	1.041	-.015	.050		5.1	1.55	1.49	6699	2600

\*\*SIZES -12 THRU -23 STANDARD MATERIAL- CARBON STEEL; OPTIONAL MATERIAL- BERYLLIUM COPPER.

\* F.I.M. (FULL INDICATOR MOVEMENT)- MAXIMUM ALLOWABLE DEVIATION OF CONCENTRICITY BETWEEN GROOVE & SHAFT.

† BASED ON HOUSINGS/SHAFTS MADE OF COLD ROLLED STEEL. FOR AN EXPLANATION OF FORMULAS USED TO DERIVE THRUST LOAD AND OTHER PERFORMANCE DATA CONTACT THE ROTOR CLIP ENGINEERING DEPARTMENT.

\*\*\*FOR PLATED RINGS ADD .002" TO THE LISTED MAXIMUM THICKNESS. MAXIMUM THICKNESS WILL BE A MINIMUM OF .0002" LESS THAN THE LISTED GROOVE WIDTH (W) MINIMUM.



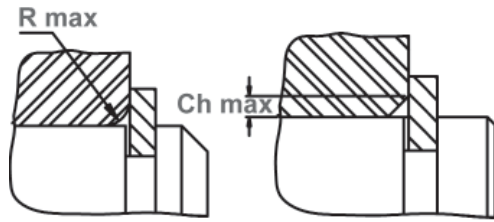

Maximum Corner Radius & Chamfer

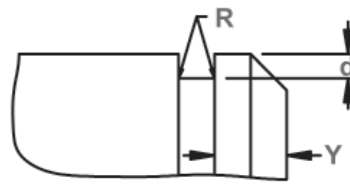

Exploded Groove Profile & Edge Margin (Y)  
Maximum bottom radii (R), sharp corners for ring sizes -12 thru -23; .003 for ring sizes -25 thru -35; .005 for sizes -37 thru -100; .010 for ring sizes -102 thru -1000



Lug Design For Sizes SH-12 thru SH-23



Alternate Design Manufacturer's Option

RING NO.	LUG HEIGHT		MAXIMUM SECTION		MINIMUM SECTION		HOLE DIAMETER		GAGING DIA.	ALLOWABLE CORNER RADII & CHAMFERS			MAX. LOAD w/ R max or Ch max (lbs.)	EDGE MARGIN	R.P.M. LIMITS Standard Material			
	H	Tol.	S max	Tol.	S min	Tol.	R	Tol.		Gd Max	R max	Ch max				P'r	Y	RPM
**SH-12	.046	±.002	.018	±.0015	.011	±.0015	.026		.148	.010	.006	45	.012	80000				
**SH-15	.054		.026		.016		.026		.189	.015	.009	45	.015	80000				
**SH-18	.050		.025		.016		.025		.218	.014	.0085	105	.018	80000				
**SH-19	.056		.026	±.002	.016	±.002	.026		.229	.0145	.009	105	.018	80000				
**SH-21	.056		.028		.017		.026		.252	.015	.009	105	.021	80000				
**SH-23	.056	.030		.019		.026	.272	.0165	.010	105	.021	80000						
SH-25	.080	±.003	.035	±.003	.025	±.003	.041	+.010 -.002	.290	.018	.011	470	.030	80000				
SH-27	.081		.035		.024		.041		.315	.0175	.0105	470	.031	76000				
SH-28	.080		.038		.025		.041		.326	.020	.012	470	.030	74000				
SH-31	.087		.040		.026		.041		.357	.020	.012	470	.033	70000				
SH-34	.087		.042		.0265		.041		.390	.021	.0125	470	.033	64000				
SH-35	.087		.046		.029		.041		.405	.023	.014	470	.036	62000				
SH-37	.088		.050		.0305		.041		.433	.026	.0155	470	.036	60000				
SH-39	.087		.052		.031		.041		.452	.027	.016	470	.037	56500				
SH-40	.087		.054		.033		.041		.468	.0285	.017	470	.036	55000				
SH-43	.088		.055		.033		.041		.501	.029	.0175	470	.039	50000				
SH-46SP1	.092	.064	.038	.041	.540	.015	.017	470	.039	42000								
SH-46	.088	.060	.035	.041	.540	.031	.018	470	.039	42000								
SH-50	.108	±.004	.065	±.004	.040	±.004	.047		.574	.034	.020	910	.048	40000				
SH-55	.108		.053		.036		.047		.611	.027	.0165	910	.048	36000				
SH-56	.108		.072		.041		.047		.644	.038	.023	910	.048	35000				
SH-59	.109		.076		.043		.047		.680	.0395	.0235	910	.052	32000				
SH-62	.110		.080		.045		.047		.715	.0415	.025	910	.055	30000				
SH-66	.110		.082		.043		.047		.756	.040	.024	910	.060	29000				
SH-66	.110		.082		.043		.047		.758	.040	.024	910	.060	29000				
SH-68	.136		.084		.048		.052		.779	.042	.025	1340	.063	28000				
SH-75	.136	.092	.051	.052	.850	.046	.0275	1340	.069	26500								
SH-78	.136	.094	.052	.052	.883	.047	.028	1340	.072	25500								
SH-81	.136	.096	.054	.052	.914	.047	.028	1340	.075	24500								
SH-84	.137	.100	.057	.052	.950	.047	.028	1340	.078	24000								
SH-87	.137	±.005	.104	±.005	.057	±.005	.052	+.015 -.002	.987	.051	.0305	1340	.081	23000				
SH-93	.166		.110		.063		.078		1.054	.055	.033	1340	.084	21500				
SH-98	.167		.114		.064		.078		1.106	.056	.0335	1340	.087	20500				
SH-100	.167		.116		.065		.078		1.122	.057	.034	1340	.090	20000				
SH-102	.168		.118		.066		.078		1.147	.058	.035	1340	.093	19500				
SH-106	.181		±.006		.122		±.006		.069	±.006	.078		1.192	.060	.036	1950	.096	19000
SH-112	.182				.128				.071		.078		1.261	.063	.038	1950	.099	18800

FOR HARDNESS SPECIFICATIONS, SEE END OF THIS SECTION.

Note: Specifications listed within the catalog tables reflect Rotor Clip's standard commercial production dimensions. Published retaining ring standards including Military (MIL-DTL-21248D) / ASME / NAS / ANSI may require parts with alternative geometry. Please contact Rotor Clip Technical Sales Department to clarify conformance to specific requirements. (Tech@rotorclip.com or +1-732-469-7333.)



# SH Shaft Rings

**Axially Assembled, External**  
 Once installed in the groove of a shaft, the portion of the ring protruding from the groove (also called a "shoulder") holds an assembly in place.

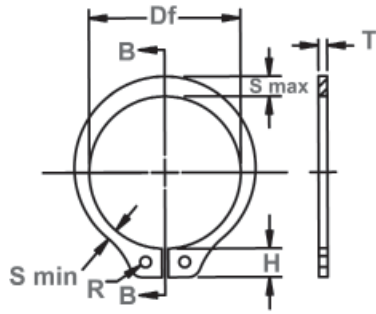

Free Diameter & Ring Measurements with Section B-B

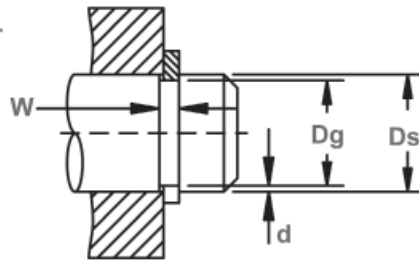

Shaft Diameter & Groove Dimensions

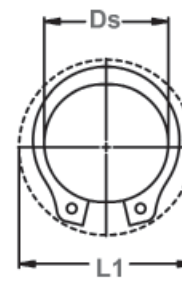

Clearance Diameter Expanded Over Shaft



Clearance Diameter & Gaging Diameter Released in Groove.

RING NO.	SHAFT DIAMETER			GROOVE SIZE			RING SIZE & WEIGHT				CLEARANCE DIA.			THRUST LD.(lbs.)			
				DIAMETER		WIDTH	DEPTH	FREE DIAMETER		THICKNESS***		Weight Per 1000 pcs.	Expanded over Shaft	Released in Groove	Sqr. Corner Abutment		
	Ds DEC	Ds FRAC	Ds mm	Dg	Tol.	W	Tol.	d	Df	Tol.	T				Tol.	lbs.	L1
SH-118	1.188	1-3/16	30.2	1.118		.056		.035	1.098		.050		5.6	1.61	1.54	7105	2950
SH-125	1.250	1-1/4	31.7	1.176		.056		.037	1.156		.050		5.9	1.69	1.62	7460	3250
SH-131	1.312	1-5/16	33.3	1.232	±.004	.056		.040	1.214	+.010	.050	±.002	6.8	1.75	1.67	7866	3700
SH-137	1.375	1-3/8	34.9	1.291	.005*	.056		.042	1.272	-.015	.050		7.2	1.80	1.72	8222	4100
SH-143	1.438	1-7/16	36.5	1.350		.056		.044	1.333		.050		8.1	1.87	1.79	8628	4500
SH-150	1.500	1-1/2	38.1	1.406		.056		.047	1.387		.050		9.0	1.99	1.90	8932	5000
SH-156	1.562	1-9/16	39.7	1.468		.068		.047	1.446		.062		12.4	2.10	2.01	11571	5200
SH-162	1.625	1-5/8	41.3	1.529		.068	+.004	.048	1.503		.062		13.2	2.17	2.08	12028	5500
SH-168	1.688	1-11/16	42.9	1.589		.068	-.000	.049	1.560		.062		14.8	2.24	2.15	12535	5850
SH-175	1.750	1-3/4	44.4	1.650	±.005	.068		.050	1.618	+.013	.062		15.3	2.31	2.21	12992	6200
SH-177	1.772	-	45.0	1.669	.005*	.068		.051	1.637	-.020	.062		15.4	2.33	2.23	13144	6400
SH-181	1.812	1-13/16	46.0	1.708		.068		.052	1.675		.062		15.6	2.38	2.28	13449	6650
SH-187	1.875	1-7/8	47.6	1.769		.068		.053	1.735		.062		17.3	2.44	2.34	13906	7000
SH-196	1.969	1-31/32	50.0	1.857		.068		.056	1.819		.062		18.0	2.57	2.46	14565	7800
SH-200	2.000	2	50.8	1.886		.068		.057	1.850		.062		19.0	2.60	2.49	14819	8050
SH-206	2.062	2-1/16	52.4	1.946		.086		.058	1.906		.078		25.0	2.68	2.57	19234	8450
SH-212	2.125	2-1/8	54.0	2.003		.086		.061	1.964		.078		26.1	2.78	2.66	19793	9150
SH-215	2.156	2-5/32	54.8	2.032		.086		.062	1.993		.078		26.3	2.81	2.69	20097	9450
SH-225	2.250	2-1/4	57.1	2.120		.086		.065	2.081	+.015	.078	±.003	27.7	2.88	2.76	21011	10350
SH-231	2.312	2-5/16	58.7	2.178		.086		.067	2.139	-.025	.078		28.0	2.94	2.81	21518	10950
SH-237	2.375	2-3/8	60.3	2.239		.086		.068	2.197		.078		29.2	3.06	2.93	22127	11400
SH-243	2.438	2-7/16	61.9	2.299		.086		.069	2.255		.078		29.5	3.07	2.94	22736	11900
SH-250	2.500	2-1/2	63.5	2.360		.086		.070	2.313		.078		29.7	3.17	3.03	23345	12350
SH-255	2.559	-	65.0	2.419		.086		.070	2.377		.078		33.9	3.18	3.04	23853	12650
SH-262	2.625	2-5/8	66.7	2.481	±.006	.086	+.005	.072	2.428		.078		35.0	3.30	3.16	24462	13350
SH-268	2.688	2-11/16	68.3	2.541	.006*	.086	-.000	.073	2.485		.078		36.0	3.37	3.23	25071	13850
SH-275	2.750	2-3/4	69.8	2.602		.103		.074	2.543		.093		42.5	3.48	3.34	30551	14400
SH-287	2.875	2-7/8	73.0	2.721		.103		.077	2.659		.093		48.5	3.60	3.45	31973	15650
SH-293	2.938	2-15/16	74.6	2.779		.103		.079	2.717	+.020	.093		50.0	3.66	3.51	32683	16400
SH-300	3.000	3	76.2	2.838		.103		.081	2.775	-.030	.093		52.0	3.60	3.44	33394	17200
SH-306	3.062	3-1/16	77.8	2.898		.103		.082	2.832		.093		47.5	3.74	3.58	34003	17750
SH-312	3.125	3-1/8	79.4	2.957		.103		.084	2.892		.093		58.0	3.85	3.69	34815	18550
SH-315	3.156	3-5/32	80.2	2.986		.103		.085	2.920		.093		59.0	3.88	3.71	35119	18950
SH-325	3.250	3-1/4	82.5	3.076		.103		.087	3.006		.093		62.0	3.93	3.76	36134	20000
SH-334	3.346	3-11/32	85.0	3.166		.103		.090	3.092		.093		64.0	4.02	3.85	37251	21000
SH-343	3.438	3-7/16	87.3	3.257		.103		.090	3.179		.093		66.0	4.14	3.96	38266	21900
SH-350	3.500	3-1/2	88.9	3.316		.120		.092	3.237		.109		72.0	4.16	3.98	45574	22800

\* F.I.M. (FULL INDICATOR MOVEMENT)- MAXIMUM ALLOWABLE DEVIATION OF CONCENTRICITY BETWEEN GROOVE & SHAFT.  
 † BASED ON HOUSINGS/SHAFTS MADE OF COLD ROLLED STEEL. FOR AN EXPLANATION OF FORMULAS USED TO DERIVE THRUST LOAD AND OTHER PERFORMANCE DATA CONTACT THE ROTOR CLIP ENGINEERING DEPARTMENT.  
 \*\*\*FOR PLATED RINGS ADD .002" TO THE LISTED MAXIMUM THICKNESS. MAXIMUM THICKNESS WILL BE A MINIMUM OF .0002" LESS THAN THE LISTED GROOVE WIDTH (W) MINIMUM.





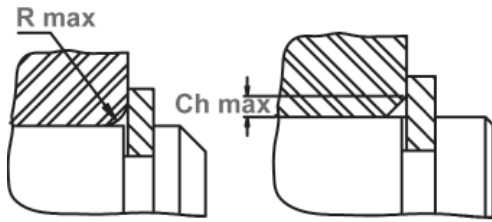

Maximum Corner Radius & Chamfer

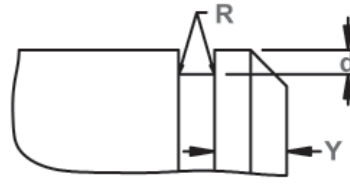

Exploded Groove Profile & Edge Margin (Y)  
Maximum bottom radii (R), sharp corners for ring sizes -12 thru -23; .003 for ring sizes -25 thru -35; .005 for sizes -37 thru -100; .010 for ring sizes -102 thru -1000



Lug Design For Sizes SH-12 thru SH-23



Alternate Design Manufacturer's Option

RING NO.	LUG HEIGHT		MAXIMUM SECTION		MINIMUM SECTION		HOLE DIAMETER		GAGING DIA.	ALLOWABLE CORNER RADII & CHAMFERS		MAX. LOAD w/ R max or Ch max (lbs.)	EDGE MARGIN	R.P.M. LIMITS Standard Material
	H	Tol.	S max	Tol.	S min	Tol.	R	Tol.		Gd Max.	R max			
	SH-118	.182		.132		.072		.078		1.325	.064	.0385	1950	.105
SH-125	.183		.140		.076		.078		1.396	.068	.041	1950	.111	17000
SH-131	.183		.146		.076		.078		1.458	.068	.041	1950	.120	16500
SH-137	.184		.152		.082		.078		1.529	.072	.043	1950	.126	16000
SH-143	.184		.160		.086		.078		1.600	.076	.045	1950	.132	15000
SH-150	.214	±.004	.168	±.006	.091	±.006	.120		1.668	.079	.047	1950	.141	14800
SH-156	.235		.172		.093		.125		1.740	.082	.049	3000	.141	14000
SH-162	.235		.180		.097		.125		1.812	.087	.052	3000	.144	13200
SH-168	.235		.184		.099		.125		1.877	.090	.054	3000	.148	13000
SH-175	.237		.188		.101		.125		1.945	.091	.054	3000	.150	12200
SH-177	.237		.190		.102		.125		1.967	.092	.055	3000	.154	11700
SH-181	.262		.192		.102		.125		2.010	.092	.055	3000	.156	11500
SH-187	.262		.196		.104		.125		2.076	.094	.056	3000	.159	11000
SH-196	.262		.200		.106		.125		2.170	.094	.056	3000	.168	10500
SH-200	.262		.204		.108		.125		2.205	.096	.057	3000	.171	10000
SH-206	.267		.208		.111		.125		2.275	.098	.059	5000	.174	9600
SH-212	.280		.212		.113		.125	+0.015	2.337	.098	.059	5000	.183	9500
SH-215	.280		.212		.113		.125	-.002	2.366	.097	.058	5000	.186	9400
SH-225	.280		.220		.116		.125		2.466	.100	.060	5000	.195	9200
SH-231	.280		.222		.118		.125		2.528	.100	.060	5000	.201	9000
SH-237	.292		.224		.119		.125		2.591	.100	.060	5000	.204	8800
SH-243	.268	±.005	.228	±.007	.120	±.007	.125		2.657	.102	.061	5000	.207	8600
SH-250	.292		.232		.122		.125		2.724	.104	.062	5000	.210	8400
SH-255	.292		.238		.125		.125		2.792	.108	.065	5000	.210	8200
SH-262	.292		.242		.127		.125		2.860	.1095	.066	5000	.216	8000
SH-268	.292		.292		.129		.125		2.926	.1115	.067	5000	.219	7900
SH-275	.324		.248		.131		.125		2.992	.112	.067	7350	.222	7600
SH-287	.324		.256		.133		.125		3.122	.115	.069	7350	.231	7300
SH-293	.324		.260		.136		.125		3.187	.116	.070	7350	.237	7200
SH-300	.264		.264		.138		.125		3.252	.117	.070	7350	.243	6700
SH-306	.300		.300		.131		.125		3.294	.107	.064	7350	.246	6600
SH-312	.324		.272		.141		.125		3.383	.120	.072	7350	.252	6600
SH-315	.324		.274		.143		.125		3.415	.1205	.072	7350	.255	6500
SH-325	.300		.300	±.008	.145	±.008	.125		3.515	.123	.074	7350	.261	6400
SH-334	.300		.300		.147		.125		3.613	.126	.076	7350	.270	6000
SH-343	.300		.300		.148		.125		3.712	.129	.077	7350	.270	5900
SH-350	.285		.285		.148		.125		3.764	.122	.073	10500	.276	5900

FOR HARDNESS SPECIFICATIONS, SEE END OF THIS SECTION.

Note: Specifications listed within the catalog tables reflect Rotor Clip's standard commercial production dimensions. Published retaining ring standards including Military (MIL-DTL-21248D) / ASME / NAS / ANSI may require parts with alternative geometry. Please contact Rotor Clip Technical Sales Department to clarify conformance to specific requirements. (Tech@rotorclip.com or +1-732-469-7333.)



# SH Shaft Rings

**Axially Assembled, External**  
Once installed in the groove of a shaft, the portion of the ring protruding from the groove (also called a "shoulder") holds an assembly in place.

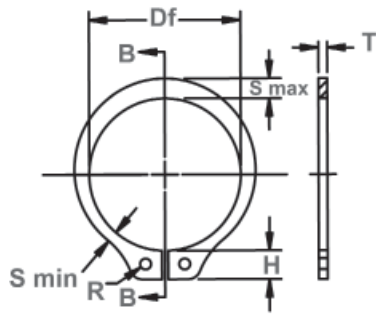

Free Diameter & Ring Measurements with Section B-B

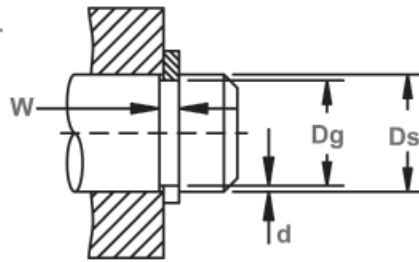

Shaft Diameter & Groove Dimensions

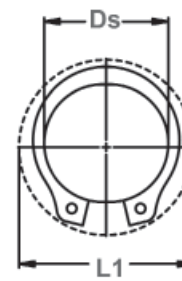

Clearance Diameter Expanded Over Shaft



Clearance Diameter & Gaging Diameter Released in Groove.

RING NO.	SHAFT DIAMETER			GROOVE SIZE			RING SIZE & WEIGHT				CLEARANCE DIA.		THRUST LD. (lbs.) Sqr. Corner Abutment				
				DIAMETER		WIDTH	DEPTH	FREE DIAMETER		THICKNESS***	Weight Per 1000 pcs.	Ex-panded over Shaft	Re-leased in Groove	Ring Safety Factor of 4	Groove Safety Factor of 2		
	Ds DEC	Ds FRAC	Ds mm	Dg	Tol.	W	Tol.	d	Df	Tol.	T	Tol.	lbs.	L1	L2	Pr	Pg
SH-354	3.543	-	90.0	3.357	.120	.093	3.277	.109	.109	.109	.109	73.0	4.25	4.07	46183	23300	
SH-362	3.625	3-5/8	92.1	3.435	.120	.095	3.352	.109	.109	.109	.109	76.0	4.36	4.17	47299	24300	
SH-368	3.688	3-11/16	93.7	3.493	.120	.097	3.410	.109	.109	.109	.109	80.0	4.33	4.31	48010	25300	
SH-375	3.750	3-3/4	95.2	3.552	±.006	.120	+ .005	.099	3.468	+ .020	.109	±.003	83.0	4.52	4.33	48822	26200
SH-387	3.875	3-7/8	98.40	3.673	.006*	.120	- .000	.101	3.584	- .030	.109	.109	88.0	4.64	4.44	50446	27700
SH-393	3.938	3-15/16	100.0	3.734	.120	.102	3.642	.109	.109	.109	.109	95.0	4.70	4.50	51359	28400	
SH-400	4.000	4	101.6	3.792	.120	.104	3.700	.109	.109	.109	.109	101.0	4.76	4.56	52171	29400	
SH-412	4.125	4-1/8	104.8	3.915	.120	.105	3.800	.109	.109	.109	.109	101.2	5.00	4.78	53200	29800	
SH-425	4.250	4-1/4	108.0	4.065	.120	.092	3.989	.109	.109	.109	.109	112.0	4.98	4.80	55419	27600	
SH-437	4.375	4-3/8	111.1	4.190	.120	.092	4.106	.109	.109	.109	.109	115.0	5.22	5.04	57043	28400	
SH-450	4.500	4-1/2	114.3	4.310	.120	.095	4.223	.109	.109	.109	.109	132.0	5.37	5.18	58667	30200	
SH-475	4.750	4-3/4	120.6	4.550	.120	.100	4.458	.109	.109	.109	.109	113.0	5.74	5.52	61915	33600	
SH-500	5.000	5	127.0	4.790	.120	.105	4.692	.109	.109	.109	.109	149.0	5.85	5.64	65163	37100	
SH-525	5.250	5-1/4	133.3	5.030	.139	.110	4.927	.125	.125	.125	.125	190.0	6.17	5.95	78460	40800	
SH-550	5.500	5-1/2	139.7	5.265	±.007	.139	+ .006	.117	5.162	+ .020	.125	±.004	202.5	6.63	6.39	82215	45500
SH-575	5.750	5-3/4	146.0	5.505	.006*	.139	- .000	.122	5.396	- .040	.125	.125	220.0	6.93	6.69	85971	49600
SH-600	6.000	6	152.4	5.745	.139	.127	5.631	.125	.125	.125	.125	210.0	7.21	6.95	89625	53800	
SH-625	6.250	6-1/4	158.7	5.985	.174	.132	5.866	.156	.156	.156	.156	282.0	7.48	7.22	116522	58300	
SH-650	6.500	6-1/2	165.1	6.225	.174	.137	6.100	.156	.156	+ .020	.156	330.0	7.80	7.45	121191	62900	
SH-675	6.750	6-3/4	171.4	6.465	.174	.142	6.335	- .050	.156	.156	.156	356.0	8.10	7.82	125860	67700	
SH-700	7.000	7	177.8	6.705	.174	.147	6.570	.156	.156	.156	.156	371.0	8.23	7.94	130529	72700	
SH-725	7.250	7-1/4	184.2	6.942	.209	.154	6.775	.187	.187	.187	.187	510.0	8.70	8.40	162096	78900	
SH-750	7.500	7-1/2	190.5	7.180	.209	.160	7.009	.187	.187	.187	.187	534.0	8.98	8.66	167678	84800	
SH-775	7.750	7-3/4	196.9	7.420	±.008	.209	+ .008	.165	7.243	+ .050	.187	±.005	545.0	9.21	8.88	173261	90450
SH-800	8.000	8	203.2	7.660	.006*	.209	- .000	.170	7.478	- .130	.187	.187	640.0	9.61	9.26	178843	96100
SH-825	8.250	8-1/4	209.6	7.900	.209	.175	7.712	.187	.187	.187	.187	665.0	9.87	9.52	184426	102100	
SH-850	8.500	8-1/2	215.9	8.140	.209	.180	7.947	.187	.187	.187	.187	692.0	10.12	9.76	190008	108100	
SH-875	8.750	8-3/4	222.3	8.380	.209	.185	8.181	.187	.187	.187	.187	712.0	10.40	10.00	195591	114450	
SH-900	9.000	9	228.6	8.620	.209	.190	8.415	.187	.187	.187	.187	737.0	10.60	10.22	201173	120800	
SH-925	9.250	9-1/4	234.9	8.860	.209	.195	8.650	.187	.187	.187	.187	760.0	10.85	10.50	206756	128225	
SH-950	9.500	9-1/2	241.3	9.100	.209	.200	8.885	.187	.187	.187	.187	785.0	11.10	10.70	212338	134200	
SH-975	9.750	9-3/4	247.6	9.338	.209	.206	9.120	.187	.187	.187	.187	845.0	11.35	10.95	217921	142000	
SH-1000	10.000	10	254.0	9.575	.209	.212	9.355	.187	.187	.187	.187	910.0	11.60	11.20	223503	149800	

\* F.I.M. (FULL INDICATOR MOVEMENT)- MAXIMUM ALLOWABLE DEVIATION OF CONCENTRICITY BETWEEN GROOVE & SHAFT.

† BASED ON HOUSINGS/SHAFTS MADE OF COLD ROLLED STEEL. FOR AN EXPLANATION OF FORMULAS USED TO DERIVE THRUST LOAD AND OTHER PERFORMANCE DATA CONTACT THE ROTOR CLIP ENGINEERING DEPARTMENT.

\*\*\*FOR PLATED RINGS ADD .002" TO THE LISTED MAXIMUM THICKNESS. MAXIMUM THICKNESS WILL BE A MINIMUM OF .0002" LESS THAN THE LISTED GROOVE WIDTH (W) MINIMUM.

Note: Specifications listed within the catalog tables reflect Rotor Clip's standard commercial production dimensions. Published retaining ring standards including Military (MIL-DTL-21248D) / ASME / NAS / ANSI may require parts with alternative geometry. Please contact Rotor Clip Technical Sales Department to clarify conformance to specific requirements. (Tech@rotorclip.com or +1-732-469-7333.)

HARDNESS RANGES: STAINLESS STEEL RINGS (PH 15-7MO)

RING TYPE	SIZE RANGE	SCALE	ROCKWELL HARDNESS
SH	25-81	30N	63-69.5
	87+	C	44-51



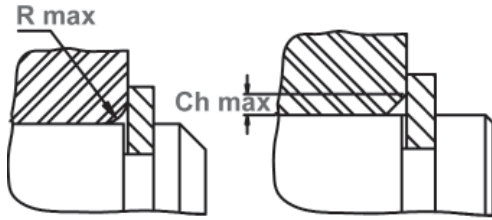

Maximum Corner Radius & Chamfer

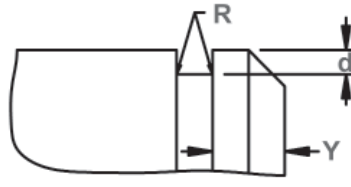

Exploded Groove Profile & Edge Margin (Y)  
Maximum bottom radii (R), sharp corners for ring sizes -12 thru -23; .003 for ring sizes -25 thru -35; .005 for sizes -37 thru -100; .010 for ring sizes -102 thru -1000



Lug Design For Sizes SH-12 thru SH-23

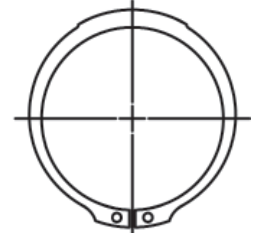

Alternate Design Manufacturer's Option

RING NO.	LUG HEIGHT		MAXIMUM SECTION		MINIMUM SECTION		HOLE DIAMETER		GAGING DIA.	ALLOWABLE CORNER RADII & CHAMFERS		MAX. LOAD w/ R max or Ch max (lbs.)	EDGE MARGIN	R.P.M. LIMITS Standard Material
	H	Tol.	S max	Tol.	S min	Tol.	R	Tol.		Gd Max.	R max			
SH-354	.310		.310		.149		.125		3.809	.123	.074	10500	.279	5800
SH-362	.310		.310		.153		.125		3.898	.127	.076	10500	.285	5700
SH-368	.310		.310		.156		.125	+.015	3.966	.130	.078	10500	.291	5600
SH-375	.342	±.005	.342	±.008	.160	±.008	.125	-.002	4.037	.133	.080	10500	.297	5500
SH-387	.310		.310		.163		.125		4.169	.137	.082	10500	.303	5100
SH-393	.310		.310		.163		.125		4.230	.137	.082	10500	.306	5200
SH-400	.342		.342		.163		.125		4.288	.135	.081	10500	.312	5000
SH-412	.380		.318		.165		.125		4.410	.135	.081	10500	.315	4900
SH-425	.342		.342		.176		.125		4.558	.146	.088	10500	.276	4800
SH-437	.342		.342		.176		.125		4.683	.146	.088	10500	.276	4700
SH-450	.405		.405		.185		.125		4.860	.102	.061	10500	.285	4500
SH-475	.405		.405		.136		.125		4.996	.115	.069	10500	.300	4200
SH-500	.405	±.008	.405	±.010	.194	±.010	.156		5.346	.165	.099	10500	.315	4000
SH-525	.435		.435		.211		.156		5.605	.169	.101	13500	.330	3900
SH-550	.497		.435		.209		.156		5.867	.175	.105	13500	.351	3700
SH-575	.518		.435		.220		.156		6.134	.184	.110	13500	.366	3500
SH-600	.540		.435		.211		.156		6.302	.143	.086	13500	.381	3400
SH-625	.561		.485		.176		.156		6.568	.148	.089	21000	.396	3100
SH-650	.586		.485		.236		.156		6.905	.191	.114	21000	.411	3000
SH-675	.608		.515		.246		.187	+.020	7.172	.200	.120	21000	.426	3000
SH-700	.530		.515		.256		.187	-.005	7.439	.208	.125	21000	.441	2900
SH-725	.660		.545		.267		.187		7.700	.214	.128	30000	.460	2800
SH-750	.676		.545		.277		.187		7.963	.220	.132	30000	.480	2700
SH-775	.660	±.012	.560	±.015	.285	±.015	.187		8.228	.227	.136	30000	.495	2600
SH-800	.735		.560		.294		.187		8.493	.235	.141	30000	.510	2500
SH-825	.735		.580		.304		.187		8.758	.242	.146	30000	.525	2400
SH-850	.735		.580		.314		.187		9.023	.250	.150	30000	.540	2300
SH-875	.735		.591		.322		.187		9.280	.258	.155	30000	.555	2200
SH-900	.735		.609		.333		.187		9.557	.267	.160	30000	.570	2200
SH-925	.735		.625		.341		.187		9.830	.274	.164	30000	.585	2100
SH-950	.735		.642		.350		.187		10.086	.281	.168	30000	.600	2100
SH-975	.735		.658		.358		.187		10.340	.287	.172	30000	.618	2000
SH-1000	.735		.675		.367		.187		10.610	.294	.176	30000	.636	2000

LARGER SIZES MAY BE AVAILABLE UPON REQUEST.

HARDNESS RANGES: CARBON STEEL RINGS (SAE 1060-1090)

RING TYPE	SIZE RANGE	SCALE	ROCKWELL HARDNESS
SH	12-23	15N	84-86
	25-46	30N	69.5-73
	50-81	30N	66-71
	84-102	C	47-53
	106-343	C	47-52
	350-700	C	44-51
	725-1000	C	40-47

HARDNESS RANGES: BERYLLIUM COPPER RINGS

RING TYPE	SIZE RANGE	SCALE	ROCKWELL HARDNESS
SH	12-23	15N	77-82*
	25-102	30N	56.5-62
	106+	C	37-43

\*HARDNESS CAN NOT BE CHECKED WITH ANY DEGREE OF ACCURACY DIRECTLY ON THESE RINGS.

