

KG Spiral Housing Rings

Internal, Heavy Duty

The greatest size range and thrust capacity make these rings the only choice for applications that require minimum deflection or thrust loads that demand a deep groove capacity.

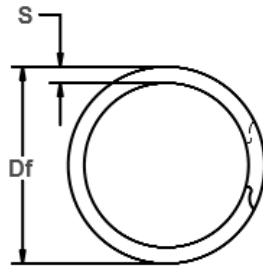

Free Diameter & Ring Measurements

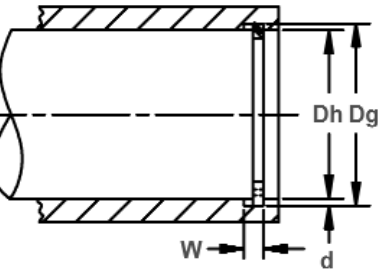
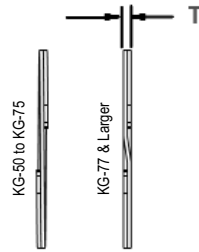

Housing Diameter & Groove Dimensions

RING NO.	HOUSING DIAMETER	GROOVE SIZE					RING SIZE						THRUST LOAD (lbs.)		
		DIAMETER		WIDTH		DEPTH	FREE DIAMETER			THICKNESS		SECTION		RING Safety factor of 3	GROOVE Safety factor of 2
		(In.)	Dg	Tol.	W	Tol.	d	Df	Tol.	T	Tol.	S	Tol.		
KG-50	.500	.530		.039		.015	.538		.035		.045		2530	530	
KG-51	.512	.542		.039		.015	.550		.035		.045		2590	540	
KG-56	.562	.596	+ .002	.039		.017	.605		.035		.055		2840	680	
KG-62	.625	.665	- .002	.039		.020	.675		.035		.055		3160	880	
KG-68	.688	.732		.039		.022	.743		.035		.065		3480	1070	
KG-75	.750	.796		.039	+ .003	.023	.807		.035		.065		3790	1220	
KG-77	.777	.825		.046	- .000	.024	.836		.042		.075		4720	1320	
KG-81	.812	.862		.046		.025	.873		.042		.075		4930	1440	
KG-86	.866	.920		.046		.027	.931		.042		.075		5260	1650	
KG-87	.875	.931	+ .003	.046		.028	.943		.042		.085		5310	1730	
KG-90	.901	.959	- .003	.046		.029	.972	+ .013	.042	+ .002	.085		5470	1850	
KG-93	.938	1.000		.046		.031	1.013	- .000	.042	- .002	.085	+ .004	5690	2060	
KG-100	1.000	1.066		.046		.033	1.080		.042		.085	- .004	6070	2330	
KG-102	1.023	1.091		.046		.034	1.105		.042		.085		6210	2460	
KG-106	1.062	1.130		.056		.034	1.138		.050		.103		7010	2550	
KG-112	1.125	1.197		.056		.036	1.205		.050		.103		7420	2860	
KG-118	1.188	1.262		.056		.037	1.271		.050		.103		7840	3110	
KG-125	1.250	1.330	+ .004	.056		.040	1.339		.050		.103		8250	3530	
KG-131	1.312	1.396	- .004	.056		.042	1.406		.050		.118		8660	3900	
KG-137	1.375	1.461		.056	+ .004	.043	1.471		.050		.118		9070	4180	
KG-143	1.439	1.528		.056	- .000	.045	1.539		.050		.118		9490	4580	
KG-145	1.456	1.548		.056		.046	1.559		.050		.118		9610	4730	
KG-150	1.500	1.594		.056		.047	1.605		.050		.118		9900	4980	
KG-156	1.562	1.658		.068		.048	1.675		.062		.128		12780	5300	
KG-162	1.625	1.725	+ .005	.068		.050	1.742	+ .020	.062	+ .003	.128		13290	5740	
KG-165	1.653	1.755	- .005	.068		.051	1.772	- .000	.062	- .003	.128		13520	5960	
KG-168	1.688	1.792		.068		.052	1.810		.062		.128		13810	6210	
KG-175	1.750	1.858		.068		.054	1.876		.062		.128		14320	6680	

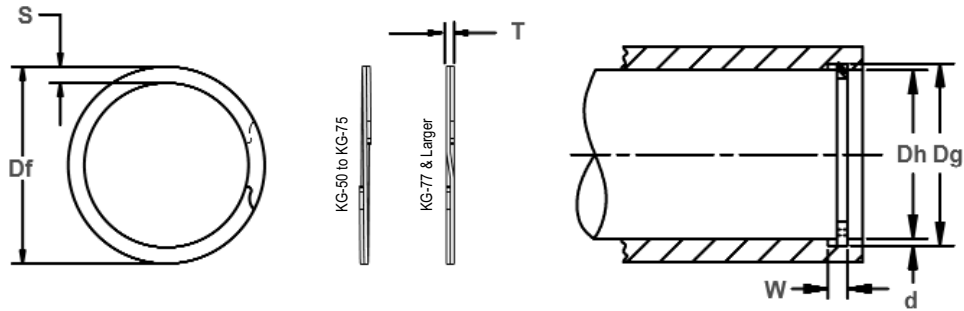

Free Diameter & Ring Measurements

Housing Diameter & Groove Dimensions

RING NO.	HOUSING DIAMETER	GROOVE SIZE					RING SIZE						THRUST LOAD (lbs.)		
		DIAMETER		WIDTH		DEPTH	FREE DIAMETER			THICKNESS		SECTION		RING Safety factor of 3	GROOVE Safety factor of 2
		(In.)	Dg	Tol.	W	Tol.	d	Df	Tol.	T	Tol.	S	Tol.		
KG-181	1.812	1.922		.068		.055	1.940		.062		.128		14820	7050	
KG-185	1.850	1.962	+ .005	.068	+ .004	.056	1.981	+ .020	.062		.158	+ .004	15130	7320	
KG-187	1.875	1.989	- .005	.068	- .000	.057	2.008	- .000	.062		.158	- .004	15340	7560	
KG-193	1.938	2.056		.068		.059	2.075		.062		.158		15850	8080	
KG-200	2.000	2.122		.068		.061	2.142		.062		.158		16360	8620	
KG-206	2.062	2.186		.086		.062	2.201		.078		.168		21220	9040	
KG-212	2.125	2.251		.086		.063	2.267		.078		.168		21870	9460	
KG-218	2.188	2.318		.086		.065	2.334		.078		.168		22520	10050	
KG-225	2.250	2.382		.086		.066	2.399		.078		.168		23160	10500	
KG-231	2.312	2.450		.086		.069	2.467	+ .025	.078		.200		23800	11280	
KG-237	2.375	2.517		.086		.071	2.535	- .000	.078		.200		24440	11920	
KG-244	2.440	2.584		.086		.072	2.602		.078	+ .003	.200		25110	12420	
KG-250	2.500	2.648		.086		.074	2.667		.078	- .003	.200		25730	13080	
KG-253	2.531	2.681		.086		.075	2.700		.078		.200		26050	13420	
KG-256	2.562	2.714	+ .006	.103	+ .005	.076	2.733		.093		.225		29940	13760	
KG-262	2.625	2.781	- .006	.103	- .000	.078	2.801		.093		.225		30680	14470	
KG-268	2.688	2.848		.103		.080	2.868		.093		.225	+ .005	31410	15200	
KG-275	2.750	2.914		.103		.082	2.934	+ .030	.093		.225	- .005	32140	15940	
KG-281	2.813	2.980		.103		.084	3.001	- .000	.093		.225		32880	16700	
KG-283	2.834	3.006		.103		.086	3.027		.093		.225		33120	17230	
KG-287	2.875	3.051		.103		.088	3.072		.093		.225		33600	17880	
KG-300	3.000	3.182		.103		.091	3.204		.093		.225		35060	18300	
KG-306	3.062	3.248		.120		.093	3.271		.111		.281		42710	20130	
KG-312	3.125	3.315		.120		.095	3.338		.111		.281		43590	20990	
KG-315	3.157	3.348		.120		.096	3.371	+ .035	.111		.281		44040	21420	
KG-325	3.250	3.446		.120		.098	3.470	- .000	.111		.281		45330	22510	
KG-334	3.346	3.546		.120		.100	3.571		.111		.281		46670	23650	
KG-347	3.464	3.675		.120		.105	3.701		.111		.281		48320	25710	

KG Spiral Housing Rings

Internal, Heavy Duty

The greatest size range and thrust capacity make these rings the only choice for applications that require minimum deflection or thrust loads that demand a deep groove capacity.

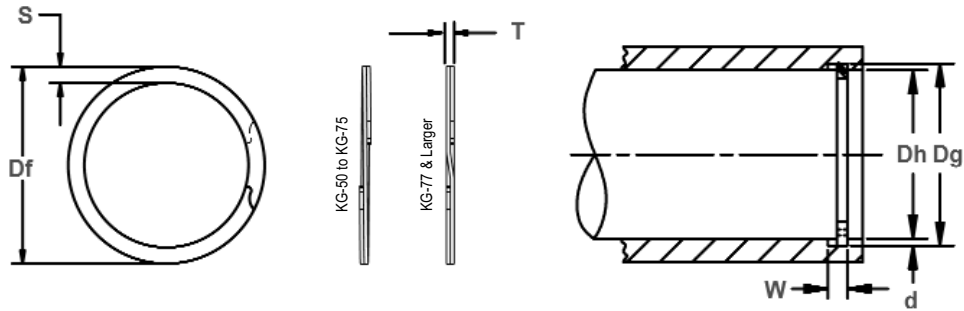

Free Diameter & Ring Measurements

Housing Diameter & Groove Dimensions

RING NO.	HOUSING DIAMETER (In.)	GROOVE SIZE					RING SIZE					THURST LOAD (lbs.)		
		DIAMETER		WIDTH		DEPTH	FREE DIAMETER		THICKNESS		SECTION		RING Safety factor of 3	GROOVE Safety factor of 2
		Dg	Tol.	W	Tol.	d	Df	Tol.	T	Tol.	S	Tol.		
KG-350	3.500	3.710		.120		.105	3.736		.111		.281		48820	25980
KG-354	3.543	3.755		.120		.106	3.781		.111		.281		49420	26550
KG-356	3.562	3.776		.120		.107	3.802		.111		.281	+ .005 - .005	49690	26940
KG-362	3.625	3.841		.120		.108	3.868		.111		.281		50560	27670
KG-375	3.750	3.974		.120		.112	4.002		.111		.312		52310	29690
KG-387	3.875	4.107	+ .006 - .006	.120	+ .005 - .000	.116	4.136	+ .035 - .000	.111	+ .003 - .003	.312		54050	31770
KG-393	3.938	4.174		.120		.118	4.203		.111		.312		54930	32850
KG-400	4.000	4.240		.120		.120	4.270		.111		.312		55800	33930
KG-412	4.125	4.365		.120		.120	4.395		.111		.312		57540	34990
KG-425	4.250	4.490		.120		.120	4.520		.111		.312		59280	36050
KG-433	4.330	4.570		.120		.120	4.600		.111		.312		60400	36730
KG-450	4.500	4.740		.120		.120	4.770		.111		.312		62770	38170
KG-462	4.625	4.865		.120		.120	4.899		.111		.312	+ .006 - .006	64510	39230
KG-475	4.750	4.995		.120		.123	5.030		.111		.312		66260	41300
KG-500	5.000	5.260		.120		.130	5.297		.111		.312		69740	45950
KG-525	5.250	5.520		.139		.135	5.559		.127		.350		83790	50100
KG-537	5.375	5.645	+ .007 - .007	.139	+ .006 - .000	.135	5.685	+ .050 - .000	.127	+ .004 - .004	.350		85780	51290
KG-550	5.500	5.770		.139		.135	5.810		.127		.350		87780	52480
KG-575	5.750	6.020		.139		.135	6.062		.127		.350		91770	54870
KG-600	6.000	6.270		.139		.135	6.314		.127		.350		95760	57260
KG-625	6.250	6.530		.174		.140	6.576		.156		.380		122520	61850
KG-650	6.500	6.790		.174		.145	6.838	+ .055 - .000	.156		.380		127420	66620
KG-662	6.625	6.925		.174		.150	6.974		.156		.380		129870	70240
KG-675	6.750	7.055	+ .008 - .008	.174	+ .008 - .000	.153	7.105		.156	+ .005 - .005	.380		132320	73000
KG-700	7.000	7.315		.174		.158	7.366		.156		.380		137230	78180
KG-725	7.250	7.575		.209		.163	7.628	+ .070 - .000	.187		.418	+ .007 - .007	170370	83530
KG-750	7.500	7.840		.209		.170	7.895		.187		.418		176240	90120
KG-775	7.750	8.100		.209		.175	8.157		.187		.418		182120	95870

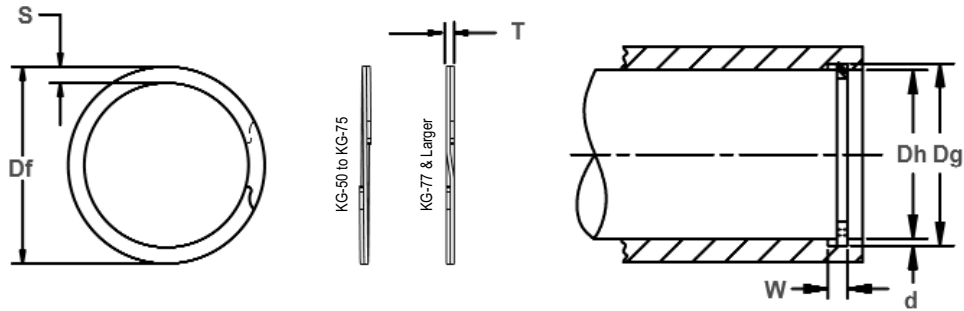

Free Diameter & Ring Measurements

Housing Diameter & Groove Dimensions

RING NO.	HOUSING DIAMETER	GROOVE SIZE					RING SIZE						THRUST LOAD (lbs.)	
		DIAMETER		WIDTH		DEPTH	FREE DIAMETER		THICKNESS		SECTION		RING Safety factor of 3	GROOVE Safety factor of 2
		(In.)	Dg	Tol.	W	Tol.	d	Df	Tol.	T	Tol.	S	Tol.	
KG-800	8.000	8.360		.209		.180	8.419		.187		.418		187990	101790
KG-825	8.250	8.620		.209		.185	8.680		.187		.437		193870	107880
KG-850	8.500	8.880		.209		.190	8.942		.187		.437		199740	114160
KG-875	8.750	9.145	+.008	.209		.198	9.209	+.070	.187		.437		205620	122460
KG-900	9.000	9.405	-.008	.209		.203	9.471	-.000	.187		.437		211490	129140
KG-925	9.250	9.669		.209		.210	9.737		.187		.437		217370	137310
KG-950	9.500	9.930		.209		.215	10.000		.187		.500		223240	144380
KG-975	9.750	10.189		.209		.220	10.260		.187		.500		229120	150620
KG-1000	10.000	10.450		.209		.225	10.523		.187		.500		234990	159040
KG-1025	10.250	10.711		.209		.235	10.786		.187		.500		246740	174420
KG-1050	10.500	10.970		.209		.231	11.047		.187		.500		240870	167370
KG-1075	10.750	11.234		.209	+.008	.242	11.313		.187	+.005	.500		252620	183890
KG-1100	11.000	11.495		.209	-.000	.248	11.575		.187	-.005	.500		258490	192830
KG-1125	11.250	11.756	+.010	.209		.253	11.838		.187		.500		264370	201190
KG-1150	11.500	12.018	-.010	.209		.259	12.102	+.120	.187		.562		270240	210540
KG-1175	11.750	12.279		.209		.265	12.365	-.000	.187		.562		276120	220100
KG-1200	12.000	12.540		.209		.270	12.628		.187		.562		281990	229020
KG-1225	12.250	12.801		.209		.276	12.891		.187		.562		287860	238990
KG-1250	12.500	13.063		.209		.282	13.154		.187		.562		293740	249170
KG-1275	12.750	13.324		.209		.287	13.417		.187		.562		299610	258660
KG-1300	13.000	13.585		.209		.293	13.680		.187		.662		305490	269240
KG-1325	13.250	13.846		.209		.298	13.943		.187		.662		311360	279100
KG-1350	13.500	14.108		.209		.304	14.207		.187		.662		317240	290100
KG-1375	13.750	14.369	+.012	.209		.310	14.470	+.140	.187		.662		323110	301300
KG-1400	14.000	14.630	-.012	.209		.315	14.732	-.000	.187		.662		328990	311730
KG-1425	14.250	14.891		.209		.321	14.995		.187		.662		334860	323340
KG-1450	14.500	15.153		.209		.327	15.259		.187		.750		340740	335160
KG-1475	14.750	15.414		.209		.332	15.522		.187		.750		346610	346150
KG-1500	15.000	15.675		.209		.338	15.785		.187		.750		352490	358380