

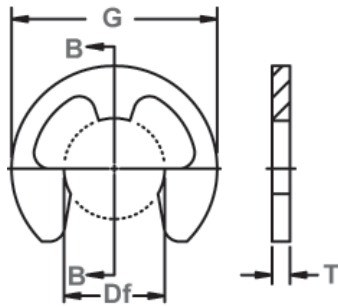

E Shaft Rings

Radially Assembled, External 'E'

Perhaps the most popular and widely used radial retaining ring is the "E" (so named because it is shaped like the letter "E".) Three prongs make contact with the bottom of the groove and provide a shoulder for effective retention of assemblies.



Free Diameter & Ring Measurements
With Section B-B

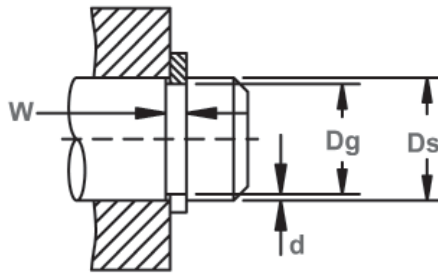

Shaft Diameter &
Groove Dimensions

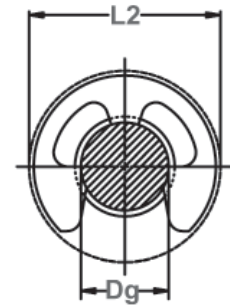

Clearance Diameter
Installed In Groove

RING NO.	SHAFT DIAMETER			GROOVE SIZE			RING SIZE & WEIGHT					CLEARANCE DIA.		THRUST LD. (lbs.)			
				DIAMETER		WIDTH	DEPTH	FREE DIAMETER		THICKNESS***		Weight Per 1000 pcs.	Free outside dia. REF.	Installed in groove	Sqr. corner abutment		
	Ds DEC	Ds FRAC	Ds mm	Dg	Tol.	W	Tol.	d	Df	Tol.	T				Tol.	lbs.	G
**E-4	.040	-	1.0	.026		.012		.007	.025		.010		.009	.079	.090	13	6
E-6	.062	1/16	1.6	.052		.012		.005	.051	+ .001	.010	± .001	.030	.156	.165	20	7
SE-6	.062	1/16	1.6	.052		.012		.005	.051	- .003	.010		.028	.140	.150	20	7
YE-6	.062	1/16	1.6	.052	+ .002	.023		.005	.051		.020		.094	.187	.200	41	7
SE-9	.094	3/32	2.4	.074	- .000	.020	+ .002	.010	.069	+ .002-.003	.015		.10	.230	.245	46	20
E-9	.094	3/32	2.4	.074	*.0015	.020	- .000	.010	.073		.015		.058	.187	.200	46	20
SE-11	.110	7/64	2.8	.079		.020		.015	.076		.015		.31	.375	.390	61	40
SE-12	.125	1/8	3.2	.095		.029		.015	.094		.025		.12	.214	.225	110	45
E-12	.125	1/8	3.2	.095		.020		.015	.094		.015		.087	.230	.240	66	45
SE-14	.140	9/64	3.6	.102		.020		.019	.100		.015		.060	.203	.215	76	60
YE-14	.140	9/64	3.6	.110		.020		.015	.108		.015		.10	.250	.265	76	45
E-14	.140	9/64	3.6	.105		.029		.017	.102	+ .001	.025		.21	.270	.285	173	60
SE-15	.156	5/32	4.0	.118	+ .002	.046		.019	.116	- .003	.042		.76	.375	.390	300	70
E-15	.156	5/32	4.0	.116		.029		.020	.114		.025		.21	.282	.295	178	75
SE-17	.172	11/64	4.4	.127	- .000	.029		.022	.125		.025		.24	.312	.325	183	90
SE-18	.188	3/16	4.8	.125	*.002	.029		.031	.122		.025		.45	.375	.39	203	135
YE-18	.188	3/16	4.8	.147		.029		.020	.145		.025	± .002	.70	.470	.485	193	90
ZE-18	.188	3/16	4.8	.125		.029		.031	.122		.025		1.05	.550	.565	203	135
E-18	.188	3/16	4.8	.147		.029		.020	.145		.025		.29	.335	.35	193	90
SE-21	.219	7/32	5.6	.188		.029		.015	.185		.025		.47	.437	.45	228	75
E-25	.250	1/4	6.3	.210		.029		.020	.207		.025		.76	.527	.54	259	115
SE-31	.312	5/16	7.9	.250		.029	+ .003	.031	.243		.025		.57	.500	.52	330	225
YE-31	.312	5/16	7.9	.250		.029	- .000	.031	.243		.025		1.220	.670	.685	325	220
SE-37	.375	3/8	9.5	.306		.039		.034	.303	+ .002	.035		1.050	.567	.587	680	300
E-37	.375	3/8	9.5	.303	+ .003	.039		.036	.300	- .004	.035		1.5	.660	.68	700	315
E-43	.438	7/16	11.1	.343	- .000	.039		.047	.337		.035		1.5	.687	.71	842	480
SE-43	.438	7/16	11.1	.380	*.004	.039		.029	.375		.035		1.0	.600	.62	812	280
E-50	.500	1/2	12.7	.396		.046		.052	.392		.042		2.5	.800	.82	1127	600
E-62	.625	5/8	15.9	.485		.046		.070	.480		.042		3.2	.940	.96	1441	1050
SE-74	.750	3/4	19.0	.625		.056		.062	.616	+ .003	.050		4.3	1.000	1.02	1979	1100
E-75	.750	3/4	19.0	.580		.056		.085	.574	- .005	.050		5.8	1.120	1.14	2030	1500
E-87	.875	7/8	22.2	.675		.056		.100	.668		.050		7.6	1.300	1.32	2385	2050
SE-98	.984	63/64	25.0	.835		.056		.074	.822		.050		9.2	1.500	1.53	2639	1750
SE-98	1.000	1	25.4	.835		.056		.082	.822		.050		9.2	1.500	1.53	2690	1900
SE-118	1.188	1-3/16	30.2	1.079	+ .005	.068	+ .004	.054	1.066	+ .006	.062	± .003	11.3	1.626	1.67	3501	1500
SE-137	1.375	1-3/8	34.9	1.230	- .000 * .005	.068	- .000	.072	1.213	- .010	.062		15.4	1.875	1.92	4162	2350

LISTED GROOVE WIDTH (W) MINIMUM.

* F.I.M. (FULL INDICATOR MOVEMENT)- MAXIMUM ALLOWABLE DEVIATION OF CONCENTRICITY BETWEEN GROOVE AND SHAFT.

** AVAILABLE IN BERYLLIUM COPPER ONLY.

† BASED ON GROOVES MADE OF COLD ROLLED STEEL. FOR AN EXPLANATION OF FORMULAS USED TO DERIVE THRUST LOAD AND OTHER PERFORMANCE DATA CONTACT THE ROTOR CLIP ENGINEERING DEPARTMENT.

*** FOR PLATED RINGS, ADD .002" TO THE LISTED MAXIMUM THICKNESS. MAXIMUM THICKNESS WILL BE A MINIMUM OF .0002" LESS THAN THE LISTED GROOVE WIDTH (W) MINIMUM.

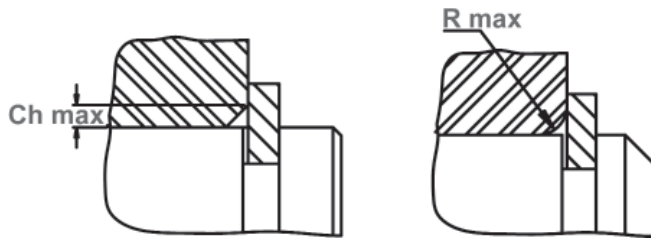

Maximum Corner Radius & Chamfer

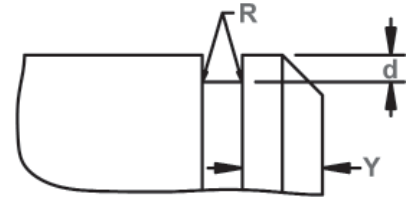

Exploded Groove Profile & Edge Margin (Y)
 Maximum bottom radii (R), Sharp corners
 for rings 4 thru 6; .005 For sizes SE9 thru 25; .010
 For sizes SE-31 thru SE-43; .015 For sizes 50 thru SE-137

RING NO.	ALLOWABLE CORNER RADII & CHAMFERS		MAX LOAD w/ R max or Ch max (in lbs.)	EDGE MARGIN	R.P.M. LIMITS Standard material
	R max	Ch max			
**E-4	.015	.010	13	.014	40000
E-6	.030	.020	20	.010	40000
SE-6	.030	.020	20	.010	40000
YE-6	.035	.025	40	.010	40000
SE-9	.053	.040	45	.020	36000
E-9	.040	.030	45	.020	36000
SE-11	.080	.060	60	.030	35000
SE-12	.040	.030	108	.030	35000
E-12	.040	.030	65	.030	35000
SE-14	.029	.022	75	.038	32000
YE-14	.040	.030	75	.030	32000
E-14	.060	.045	170	.034	32000
SE-15	.080	.060	250	.038	31000
E-15	.060	.045	175	.040	31000
SE-17	.060	.045	180	.044	30000
SE-18	.060	.045	200	.062	30000
YE-18	.060	.045	190	.040	25000
ZE-18	.060	.045	200	.062	18000
E-18	.060	.045	190	.040	30000
SE-21	.060	.045	225	.030	26000
E-25	.060	.045	255	.040	25000
SE-31	.060	.045	325	.062	22000
YE-31	.060	.045	320	.062	15000
SE-37	.060	.045	680	.068	20000
E-37	.065	.050	690	.072	20000
E-43	.065	.050	830	.094	16500
SE-43	.050	.035	800	.058	16500
E-50	.080	.060	1110	.104	14000
E-62	.080	.060	1420	.140	12000
SE-74	.057	.042	1900	.124	11000
E-75	.085	.065	2000	.170	10500
E-87	.085	.065	2350	.200	9000
SE-98	.085	.065	2700	.148	6500
SE-98	.077	.057	2700	.164	6500
SE-118	.090	.070	3450	.108	5500
SE-137	.090	.070	4100	.144	4000

LARGER SIZES MAY BE AVAILABLE UPON REQUEST.

HARDNESS RANGES: STAINLESS STEEL RINGS (PH 15-7MO)

RING TYPE	SIZE RANGE	SCALE	ROCKWELL HARDNESS
E All	E6-SE6	15N	82.5-86*
	YE6-YE14	15N	82.5-86
	E14-SE31	30N	63-69.5
	E37+	C	44-51

HARDNESS RANGES: BERYLLIUM COPPER RINGS

RING TYPE	SIZE RANGE	SCALE	ROCKWELL HARDNESS
E All	E4-SE6	15N	79-82*
	YE6-YE14	15N	79-82
	E14-SE31	30N	56.5-62
	E37+	C	37-43

HARDNESS RANGES: CARBON STEEL RINGS (SAE 1060-1090)

RING TYPE	SIZE RANGE	SCALE	ROCKWELL HARDNESS
E All	E6-SE6	15N	84.5-87*
	YE6-YE14	15N	84.5-87
	E14-SE31	30N	66.5-71
	E37+	C	47-52

*HARDNESS CAN NOT BE CHECKED WITH ANY DEGREE OF ACCURACY DIRECTLY ON THESE RINGS.

